



H2

W4

A



SISTEMA DE CONTENCIÓN VIAL METÁLICO

TVH2W4A-2

DESEMPEÑO

Nivel de Contención	22	Ancho de trabajo	W4	Nivel de severidad	A	Deflexión dinámica	1.2 m
---------------------	-----------	------------------	-----------	--------------------	----------	--------------------	--------------

PRODUCTO

- ✓ Sistema de contención lateral metálico TVH2W4A-2 ensayado bajo norma europea EN1317-2.
- ✓ Sistema compuesto por metal de nueva generación con separador y postes C cada 2.66 metros.

PERFIL

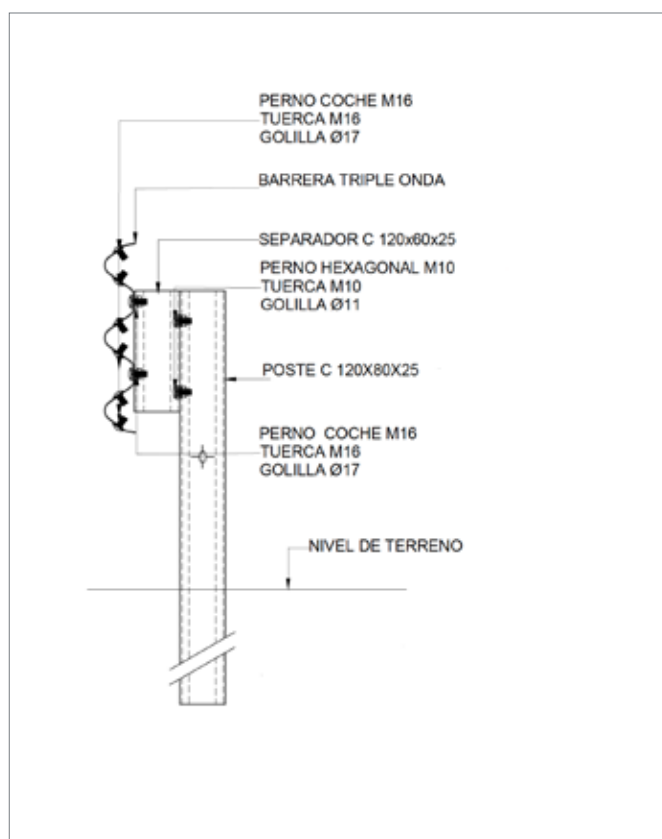
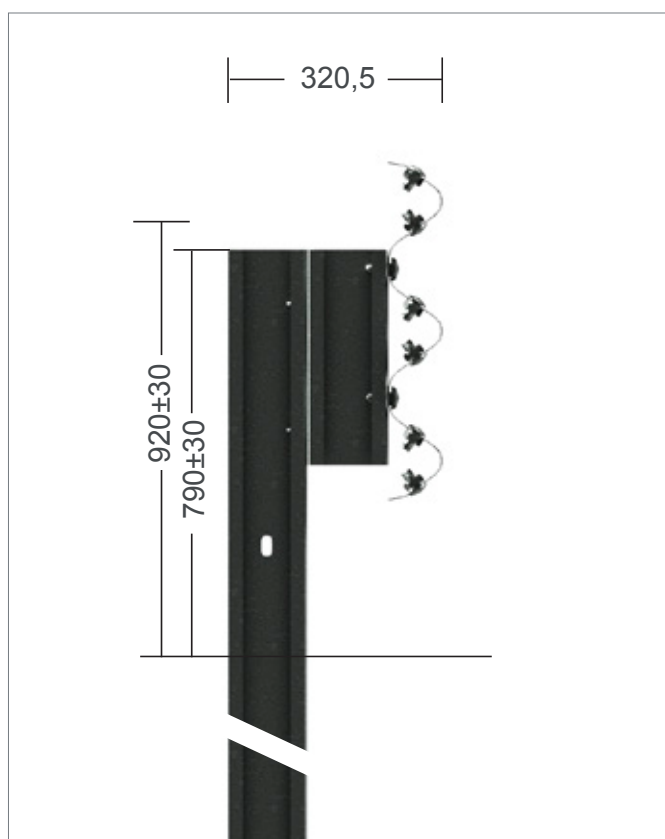



H2

W4

A



SISTEMA DE CONTENCIÓN VIAL METÁLICO

TVH2W4A-2

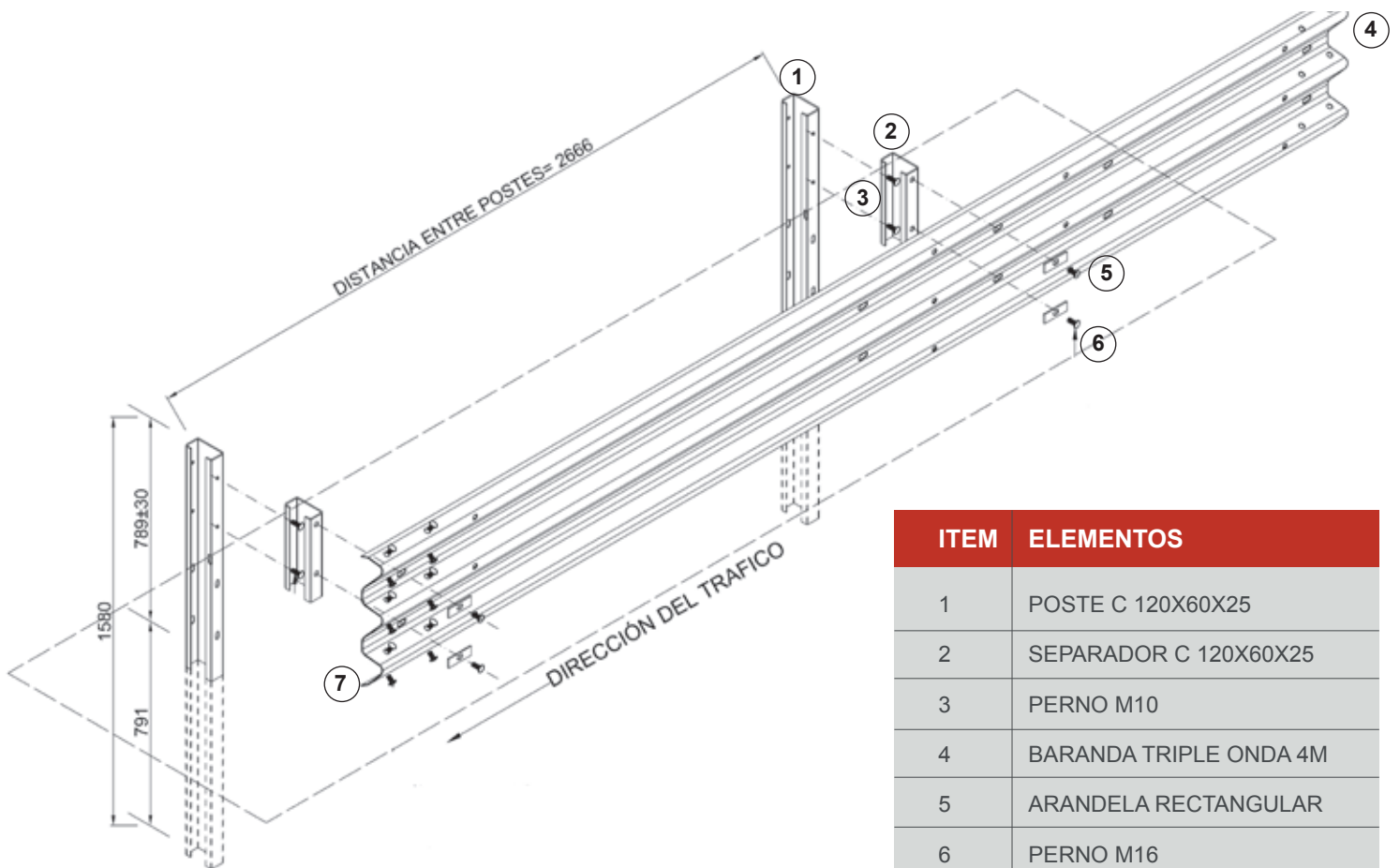

ITEM	ELEMENTOS
1	POSTE C 120X60X25
2	SEPARADOR C 120X60X25
3	PERNO M10
4	BARANDA TRIPLE ONDA 4M
5	ARANDELA RECTANGULAR
6	PERNO M16
7	PERNO M16

ALTERNATIVAS DE PROTECCIÓN AL ACERO



GALVANIZADO



CORTEN



MAGNELIS

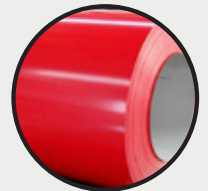

GALVANIZADO - DUPLEX